

LUBRICATE ALL SEALS WITH CLEAN HYDRAULIC OIL PRIOR TO ASSEMBLY
DO NOT USE SILICONE BASED LUBRICANTS

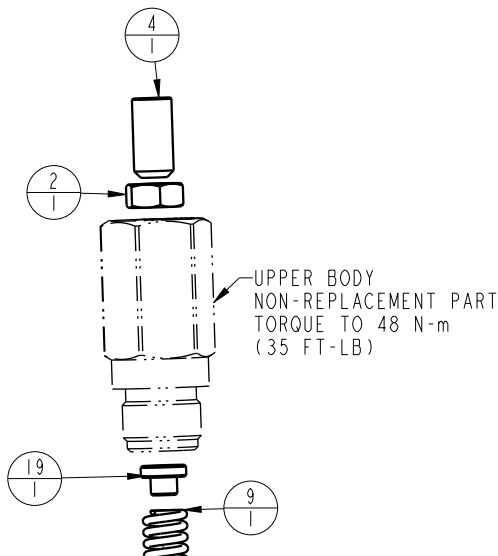

UPPER BODY
NON-REPLACEMENT PART
TORQUE TO 48 N-m
(35 FT-LB)

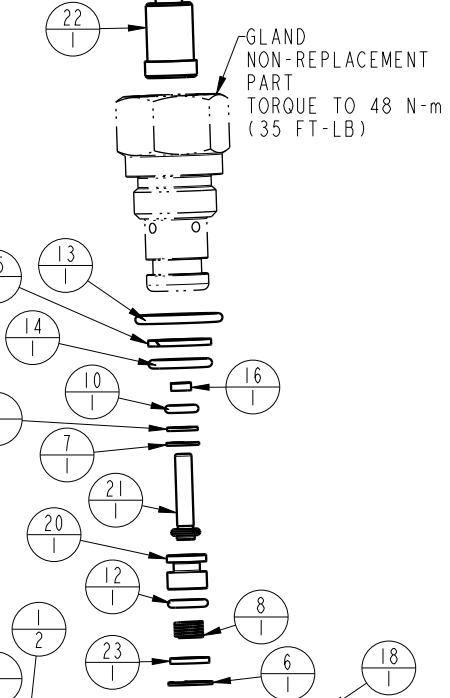

GLAND
NON-REPLACEMENT PART
TORQUE TO 48 N-m
(35 FT-LB)

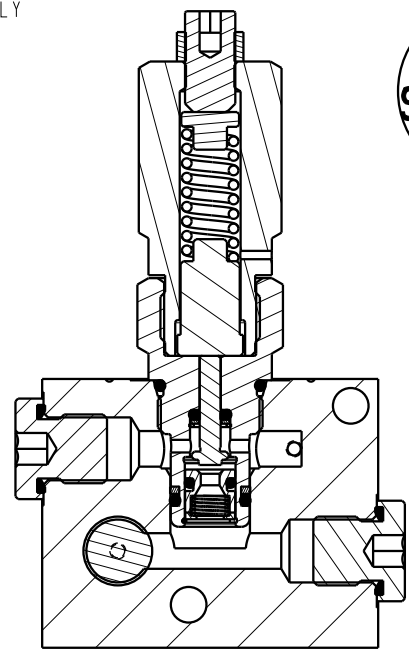

NO	QTY	PART NO	DESCRIPTION	STD SEAL KIT	SPRING KIT
1	2	215-00200	WASHER, COPPER		
2	1	21420019	NUT, HEX, 3/8-64, SST		
3	1	21430022	WASHER		
4	1	21440035	SCREW, SET, FP, 3/8-64 x 3/4, SST		
5	2	21500019	SCREW, CAP, BTNH, M3 X 6, ALY		
6	1	23002015	RETAINING RING, BASIC INTERNAL	X	X
7	1	23010006	RETAINING RING, C, EXT	X	
8	1	23355009	SPRING, COMPRESSION	X	X
9	1	23355010	SPRING, COMPRESSION		X
10	1	39000009	O-RING, (-008)	X	
11	2	39000050	O-RING, (-204)	X	
12	1	39000063	O-RING, (-010)	X	
13	1	39000064	O-RING, (17mm x 2)	X	
14	1	39000065	O-RING, (11mm x 2)	X	
15	1	39010062	BU RING, (11mm x 2)	X	
16	1	39010063	SEAL, ROD	X	
17	3	43068006	PLUG, PORT, HOLLOW HEX, G1/4		
18	1	87044003	MANIFOLD, VALVE, SEQUENCE, METRIC		
19	1	87044005	GUIDE, SPRING, UPPER, VLV, SEQ, 7MPa		
20	1	87044006	PISTON, VLV, SEQ, 7MPa		
21	1	87044007	PLUNGER, VLV, SEQ, 7MPa		
22	1	87044008	GUIDE, SPRING, LOWER, VLV, SEQ, 7MPa		
23	1	87044009	RETAINER, VLV, SEQ, 7MPa		
N/A	N/A	60704001	KIT, SEAL, VLV, SEQ, MM, LP	NOTED	N/A
N/A	N/A	L6170040	KIT, SPRING, VLV, SEQ, 7MPa	N/A	NOTED

PARTS LIST



VEKTEK, INC.
1334 E. SIXTH AVE. P.O. BOX 625
EMPORIA, KS. 66801 U.S.A.

ASSEMBLIES AFFECTED
L7041200

PARTS LIST, ASSY, VLV, SEQ, MM, 7MPa

SIZE A LPL7401

REV C

C	5862	RELEASE	ALS	11/25/25
REV	IN ACCORDANCE WITH ECN	EFFECTIVE DATE	REVISED BY	DATE
DRW BY:	DRAWING STATUS: Released			
DATE:	PRODUCTION APPROVED FOR RELEASED STATUS ONLY			